

AT&T Remote Monitor

HOMEPLUG TURBO PLC ETHERNET ADAPTER SETUP



The new  **at&t**
Your world. Delivered.™

HOMEPLUG TURBO ETHERNET ADAPTER (PLC) HELPFUL HINTS ///

We recommend registering the **XG1000 Controller** and Discovering all Cameras and Devices **PRIOR** to starting the physical installation/wiring process.

Your first step is to plug your Controller directly into your router and power it up. Then, using the supplied Cat5 cables, plug your Camera(s) directly into your router for initial Camera Discovery.

DISCOVER AND TEST CAMERAS:

1. Log in to your online account, select the **Account Settings** tab, and then select **Discovery**.
2. Press the **'START DISCOVERY'** button and wait until you get a message indicating discovery is in progress.
3. Cameras should be detected and registered automatically. If you receive a message that the camera needs to be reset, press the **Factory Defaults** button on the camera.
4. Press the **'STOP DISCOVERY'** button. Go to the **Device Overview** page and make sure that all of the devices appear in the list

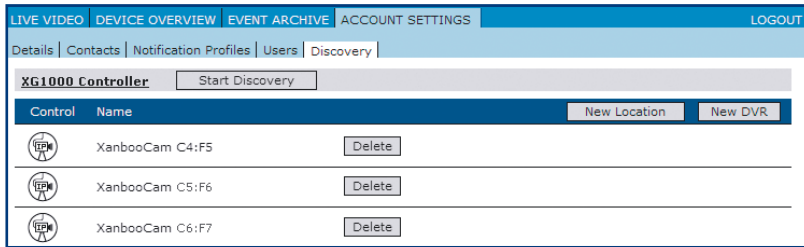

SETTING UP YOUR PLCs:

1. Connect one end of Ethernet Cable to the port on the bottom of the HomePlug Turbo PLC Ethernet Adapter. Connect the other end to a second free port on your router.

NOTE: You can connect a network hub or switch to any available Ethernet port on your router, if you need additional ports.

2. Plug the HomePlug Turbo PLC Ethernet Adapter modules directly into a free AC wall outlet. If an extension cord is needed, the length of the extension cord should be no more than 5 feet and it should not be coiled.

Confirm that the outlet is not controlled by a wall switch, as users can mistakenly switch off the power to the outlet, which will shut down the PLC and Camera.

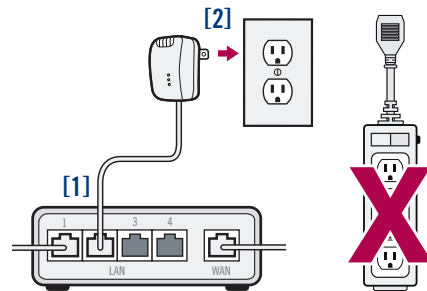

3. Bring your IP Camera, AC Power Supply, HomePlug Turbo PLC Ethernet Adapter, and Ethernet Cable to the location in your home that you wish to install your IP Camera.

Prior to running any permanent wires test the signal strength of the PLC and confirm they have **over 25% QoS**. You can obtain the QoS of the signal strength of a PLC by going to the Discovery page and hitting the **Start Discovery** button. On the bottom of the page you will see the QoS for both the host and Camera PLCs on the right hand side of the page. If the PLC does not have 25% QoS you will need to move the PLC and Camera to a new outlet. Also, confirm the AC outlet is not controlled by a wall switch.

HomePlug-PLC Device	Status	Data Rate	QoS
Host: 00:30:0A:97:4C:D4	Good connection	85.00 Mbps	(100%)
Node: 00:30:0A:8E:1B:CD	Good connection	85.00 Mbps	(100%)
Node: 00:30:0A:97:57:4B	Good connection	85.00 Mbps	(100%)
Node: 00:30:0A:97:57:54	Good connection	85.00 Mbps	(100%)

PROVIDED YOU HAVE AT LEAST 25% QoS:

4. Connect one end of the Ethernet Cable to the LAN port of the IP Camera and connect the other end to the port on the bottom of the HomePlug Turbo PLC Ethernet Adapter. Plug the HomePlug Turbo PLC Ethernet Adapter into an AC electrical outlet.
5. Plug the small end of the AC Power Supply into your IP Camera AC Adapter port and the other end into an AC electrical outlet.

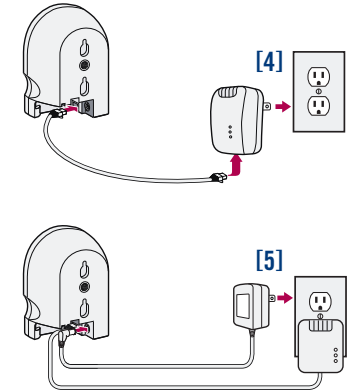

NOTE: If you prefer not to use the HomePlug Turbo PLC Ethernet Adapters, you may connect the IP Camera directly to your router or other Ethernet port in your home instead.

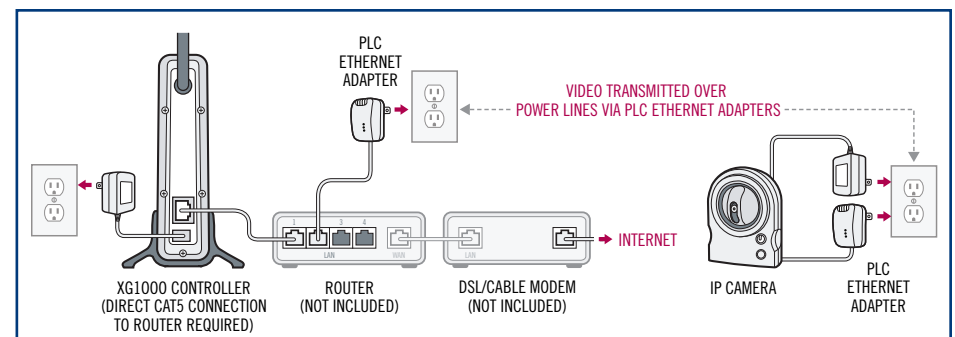

COMPLETED CONFIGURATION